

VOLUME BOOSTER

	DESCRIPTION	SUPPLY PRESSURE	PRESSURE RANGE	CONNECTION	Device	PAGE
		max. bar	bar	thread		
PRECISE	differential pressure also	17	0 ... 1 / 10	G $\frac{1}{4}$ and G $\frac{3}{8}$	R650	6.02
	ratio 1:1 up to 1:6	17	0 ... 10	G $\frac{1}{4}$ and G $\frac{3}{8}$	R750	6.03
	different ratio	17	0 ... 10	G $\frac{1}{4}$ and G $\frac{3}{8}$	R208	6.04
	differential pressure also	16	0 ... 10	G $\frac{1}{4}$ - G $\frac{1}{2}$	R03-J	6.05
	high exhaust capacity	17	0 ... 10	G $\frac{3}{4}$ and G1	R490	6.06
	different ratio, high-precision	17	0 ... 10	G $\frac{1}{2}$ and G $\frac{3}{4}$	R450	6.07
	high exhaust capacity	28	0.2 ... 18	G $\frac{1}{4}$ - G1 $\frac{1}{4}$	R116	6.08
	high volume flow	17	0 ... 10	G1 and G1 $\frac{1}{2}$	R200	6.09
high exhaust capacity	17	0 ... 10	1 $\frac{1}{2}$ NPT	R201	6.09	
STANDARD	high volume flow	21	0.2 ... 18	G $\frac{1}{4}$ - G3	R119-J	6.11
WITH RATIO	1:1 up to 1:6	17	max. 10	G $\frac{1}{4}$ and G $\frac{3}{8}$	R750	6.03
	1:1 up to 1:6 and 2:1 up to 5:1	17	max. 10	G $\frac{1}{4}$ and G $\frac{3}{8}$	R208	6.04
	1:1 up to 1:3 and 2:1 up to 3:1	17	max. 10	G $\frac{1}{2}$ and G $\frac{3}{4}$	R450	6.07
LOW PRESSURE	also for gases	20	10 ... 350/1000 mbar	G1 - G2	RZ-J	6.10
	also for gases	0,4	2 ... 55/ 160 mbar	G $\frac{1}{2}$ - G2	RGDJ-J	6.13
	also for gases	4	5 ... 350 mbar	G $\frac{1}{2}$ - G1 $\frac{1}{2}$	RGB4-J	6.13
HIGH PRESSURE	ratio 1:2 up to 1:19	260	3 ... 42 / 104	$\frac{1}{2}$ NPT and $\frac{3}{4}$ NPT	RH3-J	6.12
	made of brass	100	0.1 ... 24 / 99	G1	RLM	6.14
	made of brass	50	1 ... 15 / 50	G $\frac{1}{4}$ - G2	R120-J	6.15
MINIATURE	also for liquids	10	0 ... 6	G $\frac{1}{8}$	R035-J	www
	also for liquids	21	0.1 ... 11	G $\frac{1}{8}$ and G $\frac{1}{4}$	R364-J	www
STAINLESS STEEL	ratio 1:2 up to 1:19	310	3 ... 42 / 104	$\frac{1}{2}$ NPT and $\frac{3}{4}$ NPT	RH3-J	6.12
	made of stainless steel	100	0.1 ... 24 / 99	G1	RLE	6.14
	made of stainless steel	50	1 ... 15 / 50	G $\frac{1}{4}$ - G2	R3000-J	15.22
PRESSURE BOOSTER	1:2 up to 1:10	12	4 ... 100	G $\frac{1}{4}$ - G $\frac{3}{4}$	AM	6.16
	1:2 up to 1:5, with storage	12	4 ... 40	G $\frac{3}{8}$ and G $\frac{1}{2}$	AP	6.17
	1:2, small design	10	3 ... 16	G $\frac{1}{8}$ - G $\frac{1}{2}$	AB	6.18



6

Description	Signal-operated regulator designed to provide outlet pressure which is the sum of the input signal pressure plus a preset bias. As an option, the relay can start with bias range -0.3 bar / -4 psi. The relay can also be used as a differential pressure regulator.	
Media	compressed air or non-corrosive gases	
Supply pressure	max. 17 bar	
Pilot pressure	max. 10 bar, pilot port G $\frac{1}{4}$	
Accuracy	response sensitivity: < 1 mbar	
Air consumption	without constant bleed	
Relief capacity	110 l/min at 1.5 bar outlet and 0.35 bar overpressure above setpoint	Relieving function relieving
Gauge port	G $\frac{1}{4}$ on both sides of the body, screw plugs supplied	Mounting position any
Temperature range	0 °C to 90 °C / 32 °F to 194 °F, for appropriately conditioned compressed air down to -40 °C / -40 °F	
Material	Body: aluminium die-cast Elastomer: NBR/Buna-N Inner valve: brass	

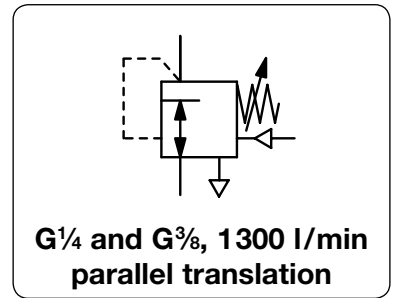

Dimensions			Flow rate	Connection thread	Supply recommended	Positive bias	Pressure range	Order number
A	B	C	m 3 /h*1	l/min*1	bar	bar	bar	
mm	mm	mm						

Positive bias relay									supply pressure max. 17 bar, relieving, without constant bleed, transmission ratio 1:1	R650
68	170	16	72	1200	G $\frac{1}{4}$	5	0... 1	0... 10	R650-02C	
						5	0... 2		R650-02D	
						8	0... 4		R650-02E	
						15	0... 10		R650-02F	
68	170	16	78	1300	G $\frac{3}{8}$	5	0... 1	0... 10	R650-03C	
						5	0... 2		R650-03D	
						8	0... 4		R650-03E	
						15	0... 10		R650-03F	



Special options, add the appropriate letter

negative bias	factory-set to -0.3 bar	R650-0..Y
NPT	connection thread	R650-0..N
tamper-proof cap	above spindle, total height 174 mm	R650-0..T

Accessories, enclosed

pressure gauge	Ø 50 mm, 0...*2 bar, G $\frac{1}{4}$	MA5002-...*2
mounting bracket	made of steel	BW00-33

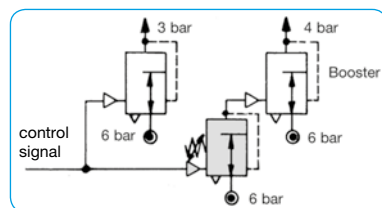

Example 1: constant differential pressure of 1 bar at high flow

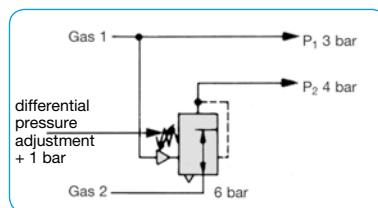

Example 2: constant differential pressure of 1 bar

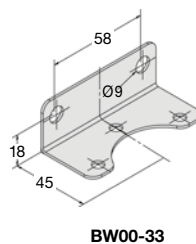
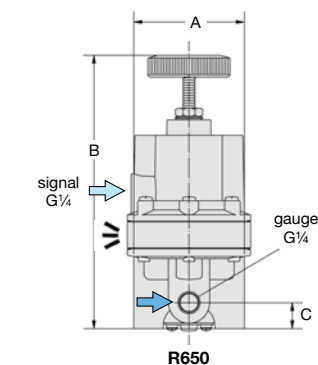
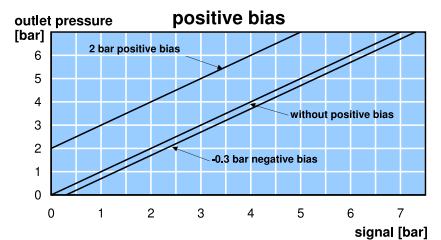
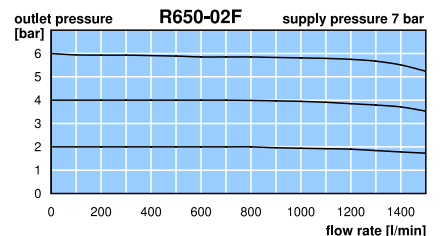
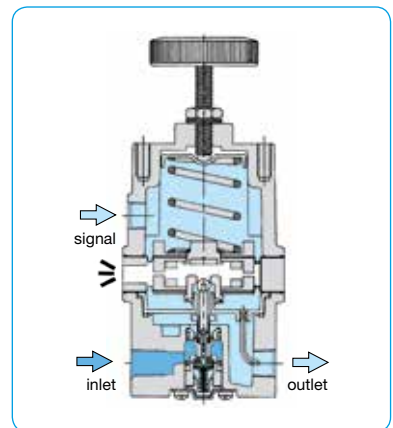

*1 at 7 bar supply pressure and 6 bar outlet pressure
*2 01 = 0...1 bar, 02 = 0...2.5 bar, 04 = 0...4 bar, 10 = 0...10 bar

Gauges: see chapter for measuring devices

PDF CAD
www.aircom.net



Order example:
R650-02C

PRECISION VOLUME BOOSTER WITH TRANSMISSION RATIO

R750

Description

The volume booster with transmission ratio amplifies the outlet pressure at a 1:1 up to 1:6 ratio by a pneumatic pilot pressure, which has no constant bleed. That signal pressure has the same function as a spring in a common regulator: generating counter pressure on the diaphragm. This force is compensated by the outlet pressure on the diaphragm's bottom side. The ratio of pilot pressure to outlet pressure depends on the size of the operating diaphragms.

Media

compressed air or non-corrosive gases

Supply pressure max. 17 bar

Pilot pressure

max. 10 bar at 1:1 ratio, 5 bar at 1:2, 3.3 bar at 1:3, 1.7 bar at 1:6, pilot port G $\frac{1}{4}$

Accuracy

at supply variation of 3.5 bar: < 7 mbar 1:1, < 10 mbar at 1:2, < 21 mbar at 1:3, < 41 mbar at 1:6
response sensitivity: < 2 mbar 1:1, < 3 mbar at 1:2, < 17 mbar at 1:3, < 23 mbar at 1:6

Air consumption

max. 3 l/min, subject to outlet pressure

Relieving function

relieving

Relief capacity

170 l/min at 1.5 bar outlet and 0.7 bar overpressure above setpoint

Gauge port

on both sides of the body, thread equal to regulator thread

Mounting position any

Temperature range

0 °C to 70 °C / 32 °F to 158 °F, for appropriately conditioned compressed air down to -40 °C / -40 °F

Material

Body: zinc die-cast Elastomer: NBR/Buna-N Inner valve: brass and stainless steel

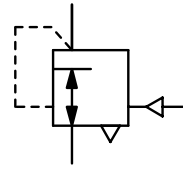

G $\frac{1}{4}$ and G $\frac{3}{8}$, 1000 l/min
1:1 up to 1:6

Dimensions			K _v -value (m ³ /h)	Flow rate m ³ /h*1 l/min*1	Connection thread G	Signal pressure max. bar	Transmission ratio signal : outlet	Order number
A	B	C						

Booster			with transmission ratio, relieving, with constant bleed,		supply pressure max. 17 bar, pressure range 0...10 bar		R750		
68	102	16	0.5	60	1000	G $\frac{1}{4}$	10	1:1	R750-02I
							5.0	1:2	R750-02K
							3.3	1:3	R750-02C
							1.7	1:6	R750-02M
68	102	16	0.5	60	1000	G $\frac{3}{8}$	10	1:1	R750-03I
							5.0	1:2	R750-03K
							3.3	1:3	R750-03C
							1.7	1:6	R750-03M



R750

Special options, add the appropriate letter

negative bias	factory-set to -0,3 bar	R750-0. .Y
NPT	connection thread	R750-0. .N
tapped exhaust	connection thread G $\frac{1}{4}$	R750-0. .X12

Accessories, enclosed

pressure gauge	Ø 50 mm, 0...*2 bar, G $\frac{1}{4}$	MA5002-...*2
mounting bracket	made of steel	BW00-33

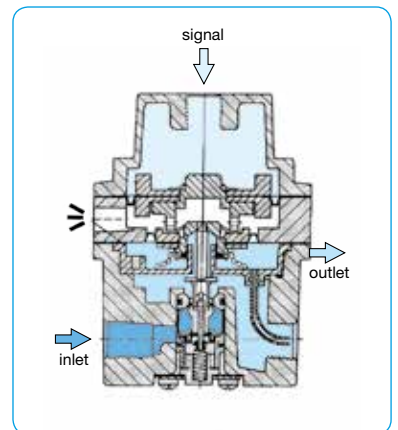

cross-section

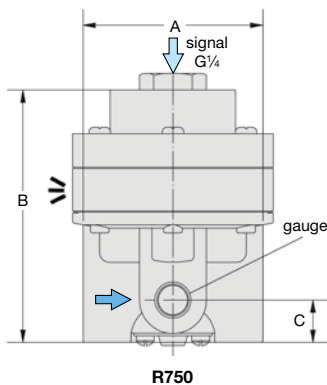

R750

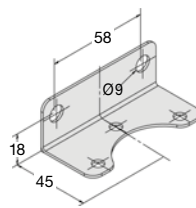

BW00-33

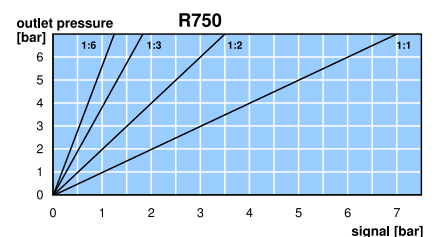
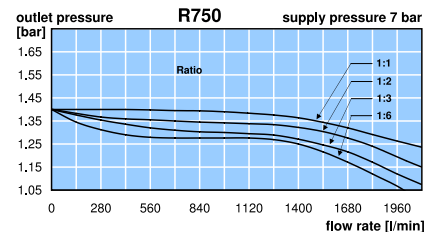

*1 at 7 bar supply pressure and 1.4 bar outlet pressure
*2 02 = 0...2.5 bar, 04 = 0...4 bar, 06 = 0...6 bar, 10 = 0...10 bar, 16 = 0...16 bar

Gauges: see chapter for measuring devices

PDF CAD
www.aircom.net



Order example:
R750-02I

PRECISION VOLUME BOOSTER WITH TRANSMISSION RATIO

R208

Description	The volume booster amplifies the volume at a 1:1 ratio of pilot pressure to outlet pressure. The pilot pressure has no constant bleed and shows the same function as a spring in a common regulator: generating counter pressure on the diaphragm.	
Media	compressed air or non-corrosive gases	
Supply pressure	max. 17 bar	
Pilot pressure	max. 10 bar at 1:1 ratio, 5 bar at 1:2, 3.3 bar at 1:3, 2.5 bar at 1:4, 1.7 bar at 1:6	Pilot port G $\frac{1}{4}$
Accuracy	at supply pressure variation of 7 bar: < 7 mbar pressure deviation	
Air consumption	max. 3 l/min, subject to outlet pressure	Relieving function relieving
Relief capacity	310 l/min at 1.5 bar outlet and 0.35 bar overpressure above setpoint	Mounting position any
Gauge port	G $\frac{1}{4}$ on both sides of the body, screw plugs supplied	
Temperature range	0 °C to 80 °C / 32 °F to 176 °F, NBR, for appropriately conditioned compr. air down to -40 °C / -40 °F	
Material	Body: aluminium die-cast Inner valve: brass and zinc-plated steel	Elastomer: NBR/Buna-N, optionally FKM

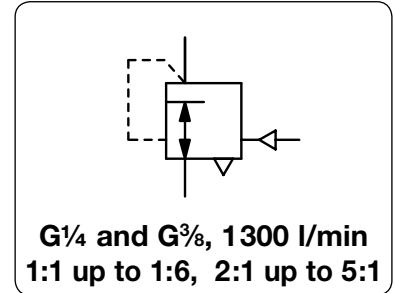

Dimensions			K _v -value	Flow rate	Connection	Pilot pressure	Transmission ratio	Order number
A	B	C	(m ³ /h)	m ³ /h*1	thread	max. bar	signal : outlet	
mm	mm	mm		l/min*1	G			

Booster			with transmission ratio, relieving, with constant bleed, pressure range 0...10 bar				R208		
76	98	24	0.7	78	1300	G $\frac{1}{4}$	10	1 : 1	R208-02I
							5.0	1 : 2	R208-02K
							3.3	1 : 3	R208-02L
76	110	24	0.7	78	1300	G $\frac{1}{4}$	2.5	1 : 4	R208-02M
							2.0	1 : 5	R208-02N
							1.7	1 : 6	R208-02O
76	98	24	0.7	78	1300	G $\frac{1}{4}$	10	2 : 1	R208-02R
								3 : 1	R208-02S
76	110	24	0.7	78	1300	G $\frac{1}{4}$	10	4 : 1	R208-02T
								5 : 1	R208-02U



R208

Special options, add the appropriate letter

G $\frac{3}{8}$	connection thread	R208-03 .
NPT	connection thread	R208-02 .N
non-relieving*3	without relieving function	R208-02 .K
tapped exhaust*3	connection thread G $\frac{1}{4}$	R208-02 .X12
bypass with restrictor	between control chamber and outlet, 1:1 only	R208-02 .X16
negative bias*3	preset to -0,24 bar, adjustable by 30 mbar	R208-02 .Y
silicone elastomer	supply pressure max. 5 bar, 1:1 only	R208-02 .A
FKM elastomer		R208-02 .V

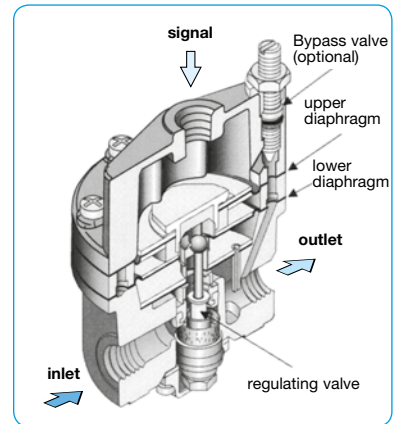

cross section

Accessories, enclosed

pressure gauge	Ø 50 mm, 0...*2 bar, G $\frac{1}{4}$	MA5002-...*2
mounting bracket	made of steel	BW00-34

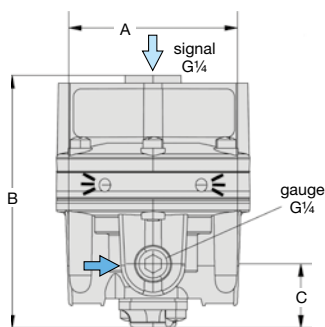

R208

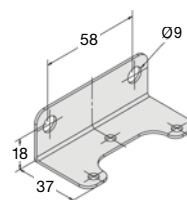

BW00-34

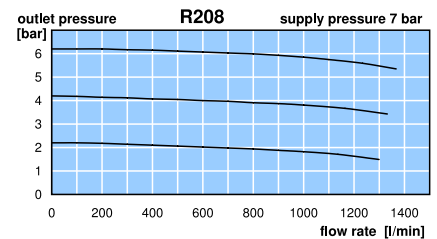

*1 at 7 bar supply pressure and 1.4 bar outlet pressure
*2 02 = 0...2.5 bar, 04 = 0...4 bar, 06 = 0...6 bar, 10 = 0...10 bar, 16 = 0...16 bar

*3 only for 1:1, 1:2, 1:3, 2:1 and 3:1

Gauges: see chapter for measuring devices

PDF CAD
www.aircom.net

Order example:
R208-02I

Description Pilot-operated volume booster with positive bias designed to supply outlet pressure equal to signal pressure plus an adjustable preset spring constant. With very high forward and reverse flow characteristics and excellent sensitivity. If requested the system pressure can also manually be adjusted up to 6 bar adding to the pilot pressure.

Media oil-free and 5 µm filtered compressed air or non-corrosive gases

Supply pressure max. 16 bar

Pilot pressure max. 10 bar, accordingly lower in the case of manual pre-pressure setting

Accuracy at supply pressure change from 2 bar to 7 bar: < 6 mbar pressure deviation
at flow rate change from 0 l/min to 20 l/min: < 20 mbar pressure deviation
response sensitivity: < 2 mbar

Air consumption 1.5 l/min at P₁= 5 bar, 2 l/min at P₁= 7 bar, 4 l/min at P₁= 10 bar, < 1% of volume flow relieving

Relieving function 700 l/min at 6 bar outlet and 0.35 bar overpressure above setpoint

Relief capacity G_{1/4} on both sides of the body, one screw plug supplied

Gauge port any

Temperature range 0 °C to 60 °C / 32 °F to 140 °F, for appropriately conditioned compressed air down to -30 °C / -22 °F

Material Body: zinc die-cast
Elastomer: NBR/Buna-N

Pilot port G_{1/8}

Mounting position any

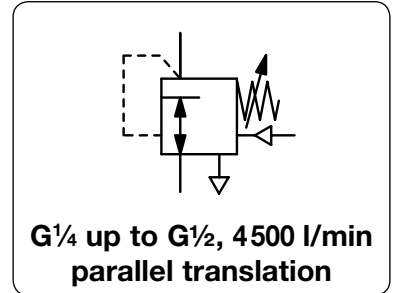

Dimensions			K _v -value	Flow rate	Connection thread	Positive bias	Pressure range	Order number
A	B	C						

Volume booster			supply pressure max. 16 bar, with constant bleed, tapped exhaust, transmission ratio 1:1					R03-J	
82	106	41	2.0	198	3300	G _{1/4} *3	without	0.05 ... 10	R03-02J
			2.3	228	3800	G _{3/8} *3			R03-03J
			2.7	270	4500	G _{1/2}			R03-04J



R03-...J

Positive bias booster			supply pressure max. 16 bar, with constant bleed, tapped exhaust, transmission ratio 1:1					R03-J .	
82	142	41	2.0	198	3300	G _{1/4} *3	0 ... 1 bar	0.05 ... 10	R03-02J1
			2.3	228	3800	G _{3/8} *3			R03-03J1
			2.7	270	4500	G _{1/2}			R03-04J1
82	180	41	2.0	198	3300	G _{1/4} *3	0 ... 6 bar	0.05 ... 10	R03-02J6
			2.3	228	3800	G _{3/8} *3			R03-03J6
			2.7	270	4500	G _{1/2}			R03-04J6



R03-...J1

Accessories, enclosed

pressure gauge Ø 50 mm, 0...*2 bar, G_{1/4}

mounting nut made of plastic

mounting bracket made of steel

for R03-...J1 MA5002-...*2
M30x1,5K
BW00-36

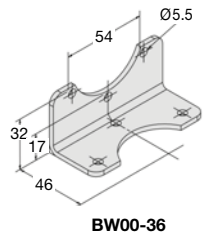
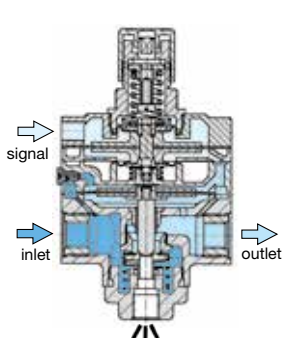

R03-...J6

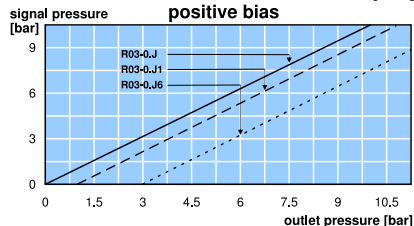
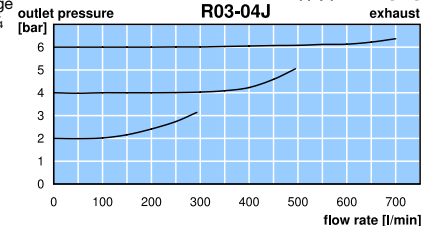
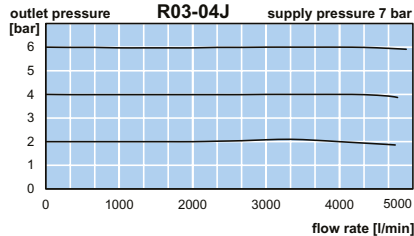
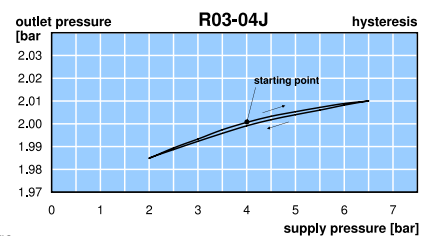
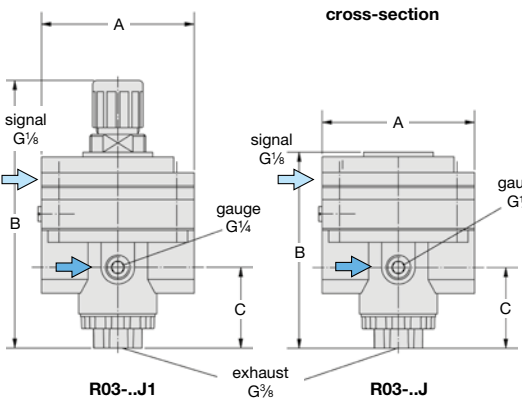
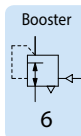

*1 at 7 bar supply pressure, 6 bar outlet pressure and 1 bar pressure drop
*2 02 = 0...2.5 bar, 04 = 0...4 bar, 06 = 0...6 bar, 10 = 0...10 bar, 16 = 0...16 bar
*3 standard unit G_{1/2} reduced to smaller threads by fittings

PRECISION VOLUME BOOSTER WITH HIGH EXHAUST

R490

Description	The volume booster amplifies the volume at a 1:1 ratio of pilot pressure to outlet pressure. The booster is a rugged precision instrument with key features providing reliable, efficient and stable operation. Very low deadband between the operation of the supply valve and exhaust valve providing excellent pressure control. High capacity exhaust valve provides efficient dynamic reverse flow characteristics. Pressure balanced supply valve prevents changes in control characteristics when supply pressure changes. Damped diaphragm control chamber provides stable operation and protects valves from damaging oscillation under high flow conditions.		
Media	compressed air or non-corrosive gases	Supply pressure	max. 17 bar
Pilot pressure	max. 10 bar; pilot port G $\frac{1}{4}$		
Accuracy	at supply pressure variation of 7 bar: < 7 mbar pressure deviation response sensitivity: 2.5 mbar	Relieving function	relieving
Air consumption	max. 3 l/min subject to outlet pressure	Mounting position	any
Relief capacity	2800 l/min at 0.35 bar overpressure above setpoint of 1.5 bar		
Gauge port	$\frac{1}{4}$ " NPT on both sides of the body, screw plugs supplied		
Temperature range	-40 °C to 93 °C / -40 °F to 199 °F		
Material	Body: aluminium die-cast Inner valve: zinc-plated steel, optionally stainless steel	Diaphragm:	NBR/Buna-N on Polyester, optionally FKM

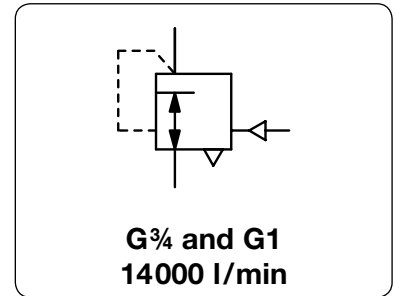

Dimensions			K _v -value	Flow rate	Connection thread	Supply pressure	Pressure range	Order number
A	B	C						
mm	mm	mm	(m ³ /h)	m ³ /h*1	l/min*1	G	max. bar	signal : outlet

Booster			transmission ratio 1:1, supply pressure max. 17 bar, relieving, with constant bleed					R490	
143	188	44	9	850	14100	G $\frac{3}{4}$	17	0 ...10	R490-06
143	188	44	9	850	14100	G1	17	0 ...10	R490-08



R490

Special options, add the appropriate letter

NPT	connection thread	R490-0 . N
external feedback	with connection thread G $\frac{1}{4}$	R490-0 . X27
FKM elastomer		R490-0 . V
inner parts SST	all	R490-0 . S

Accessories, enclosed

pressure gauge	Ø 63 mm, 0...*2 bar, G $\frac{1}{4}$	MA6302-..*2
-----------------------	--------------------------------------	-------------

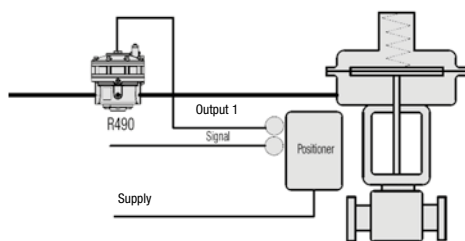
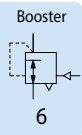

Volume booster with single acting positioner and diaphragm actuator

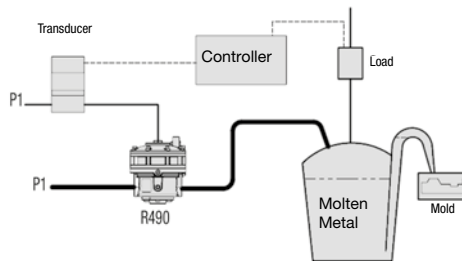

Volume booster: casting implements

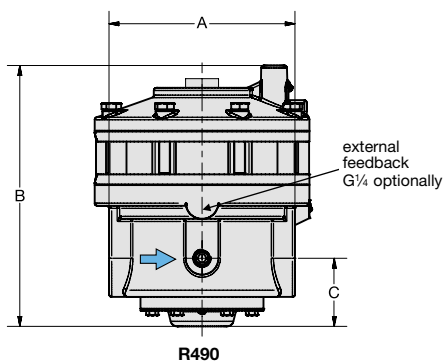

R490

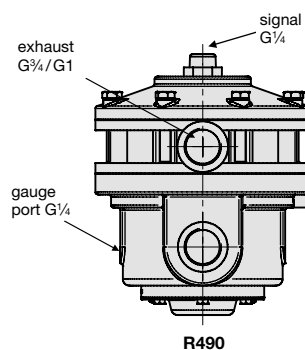

R490

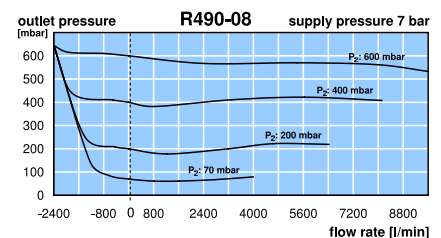
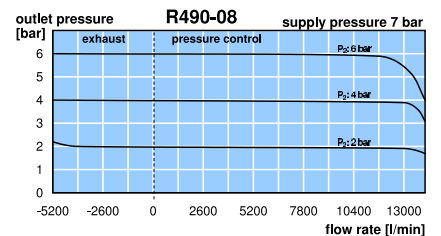

*1 at 7 bar supply pressure and 1.4 bar outlet pressure
*2 02 = 0...2.5 bar, 04 = 0...4 bar, 06 = 0...6 bar, 10 = 0...10 bar

Gauges: see chapter for measuring devices

PDF CAD
www.aircom.net



Order example:
R490-06

Description	The volume booster amplifies the volume at a 1:1 ratio of pilot pressure to outlet pressure. The pilot pressure has no constant bleed and shows the same function as a spring in a common regulator: generating counter pressure on the diaphragm. This force is compensated by the outlet pressure on the diaphragm's bottom side. The ratio of pilot pressure to outlet pressure depends on the size of the operating diaphragms.		
Media	compressed air or non-corrosive gases	Supply pressure	max. 17 bar
Pilot pressure	max. 10 bar at 1:1, 2:1 and 3:1 ratio, 5 bar at 1:2,	3.3 bar at 1:3,	pilot port: G $\frac{1}{4}$
Accuracy	at supply pressure variation of 7 bar: < 7 mbar pressure deviation response sensitivity: 2.5 mbar		
Internal air consumption	max. 3 l/min, depending on outlet pressure		
Relief capacity	1100 l/min at 0.35 bar overpressure above setpoint		
Gauge port	G $\frac{1}{4}$ on both sides of the body, screw plugs supplied		
Temperature range	0 °C to 90 °C / 32 °F to 194 °F, for appropriately conditioned compressed air down to -40 °C / -40 °F		
Material	Body: aluminium die-cast	Elastomer: NBR/Buna-N, optionally FKM	Relieving function relieving
	Inner valve: brass and aluminium		Mounting position any

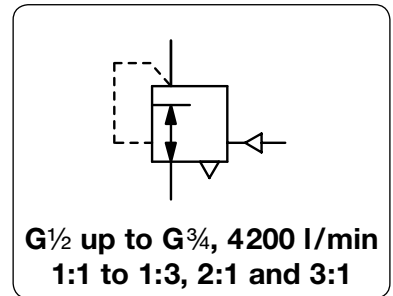

Dimensions			K _v -value	Flow rate	Connection thread	Pilot pressure	Transmission ratio	Order number
A	B	C	(m ³ /h)	m ³ /h*1	G	max. bar	signal : outlet	

Booster			with transmission ratio, supply pressure max. 17 bar relieving, with constant bleed, pressure range 0...10 bar				R450		
87	129	40	2.16	240	4000	G $\frac{1}{2}$	10	1 : 1	R450-04I
							5.0	1 : 2	R450-04K
							3.3	1 : 3	R450-04L
							10	2 : 1	R450-04M
							10	3 : 1	R450-04N
87	129	40	2.16	252	4200	G $\frac{3}{4}$	10	1 : 1	R450-06I
							5.0	1 : 2	R450-06K
							3.3	1 : 3	R450-06L
							10	2 : 1	R450-06M
							10	3 : 1	R450-06N



R450

Special options, add the appropriate letter

NPT	connection thread	R450-0..N
tapped exhaust	G $\frac{1}{2}$ connection thread, total height 148 mm	R450-0..X12
bypass with restrictor	from control chamber to outlet	1:1 only R450-0..X16
external feedback	with connection thread G $\frac{1}{8}$	R450-0..X27
FKM elastomer		R450-0..V

Accessories, enclosed

pressure gauge	Ø 63 mm, 0...*2 bar, G $\frac{1}{4}$	MA6302-..*2
mounting bracket	made of steel	BW00-47

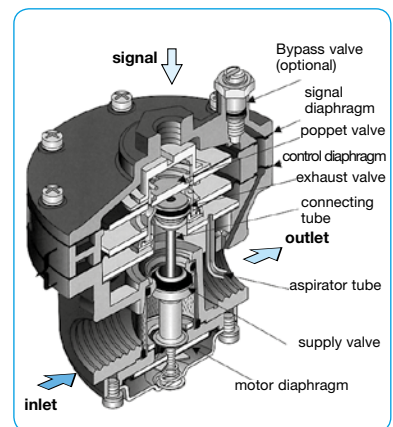

cross section

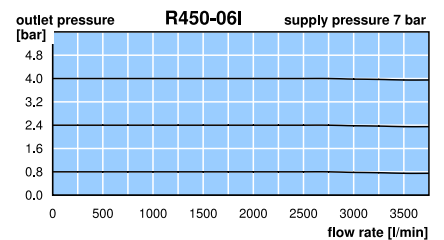
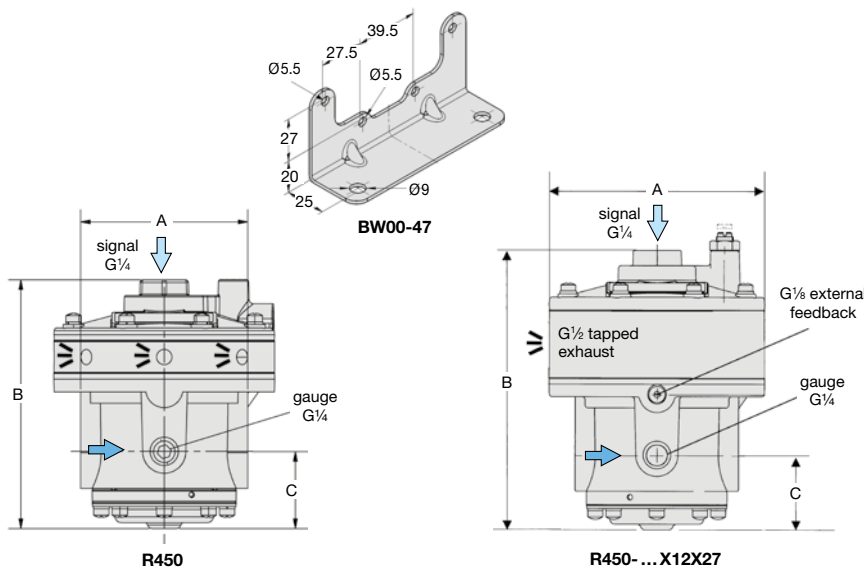

*1 at 7 bar supply pressure and 1.4 bar outlet pressure
*2 02 = 0...2.5 bar, 04 = 0...4 bar, 06 = 0...6 bar, 10 = 0...10 bar, 16 = 0...16 bar

Gauges: see chapter for measuring devices

PDF CAD
www.aircom.net

Order example:
R450-04I

PRECISION VOLUME BOOSTER WITH HIGH RELIEF CAPACITY

R116

Description	Pilot-operated regulator adapted for control by small remote pilot regulator or by proportional pressure valve. Ideal for continuous high-capacity requirements where reduced pressure must be held constant over wide variations in flow. The booster is equipped with a diaphragm. Transmission ratio 1:1 (pilot pressure to outlet pressure).		
Media	compressed air or non-corrosive gases	Mounting position	any
Supply pressure	max. 28 bar	Pilot pressure	max. 18 bar
Outlet pressure	0.2... 18 bar	Air consumption	without constant bleed
Relieving function	6500 l/min at 6 bar, see diagram		
Ports	inlet / outlet: see chart gauge P ₂ : G ¹ / ₄	exhaust: G ¹ / ₂ (up to overall size G ¹ / ₂), G ³ / ₄ (from size G ³ / ₄ on)	gauge P ₁ : G ¹ / ₂ (from size G ³ / ₄ on)
Temperature range	-18 °C to 70 °C / 0 °F to 158 °F		
Material	Body: zinc die-cast Elastomer: NBR/Buna-N	Inner valve: brass Bottom screw: reinforced nylon	

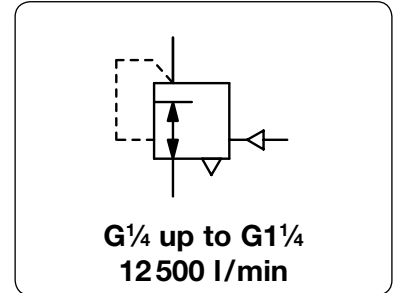

Dimensions			Nominal size	K _v -value	Flow rate		Connection thread	Order number
A	B	C	DN	(m ³ /h)	m ³ /h*1	l/min*1	G	
mm	mm	mm						

Booster with high relief capacity								P ₁ : max. 28 bar, P ₂ : 0.2... 18 bar, ratio 1:1 relieving	R116
80	129	39	15	4.3	270	4500	G ¹ / ₄	R116-02	
				4.4	290	4800	G ³ / ₈	R116-03	
				4.5	300	5000	G ¹ / ₂	R116-04	
93	149	48	25	9.5	690	11500	G ³ / ₄	R116-06	
				10.0	720	12000	G1	R116-08	
				10.4	750	12500	G ¹ / ₂	R116-10	



Special options, add the appropriate letter

NPT	connection thread	R116-..N
flange connection	see chapter SST devices / flanges	R116-..F



Accessories, enclosed

pressure gauge	Ø 50 mm, 0...*2 bar, G ¹ / ₄	for G ¹ / ₄ to G ¹ / ₂	MA5002 -*2
	Ø 63 mm, 0...*2 bar, G ¹ / ₄	for G ³ / ₄ to G ¹ / ₂	MA6302 -*2
mounting bracket	made of aluminium		BW00-32

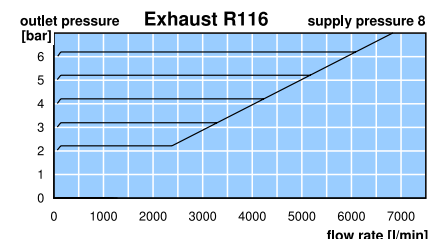
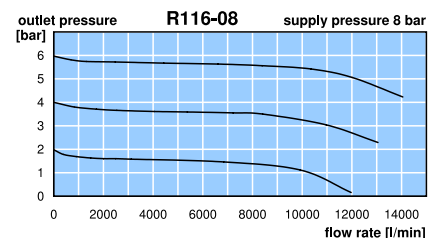
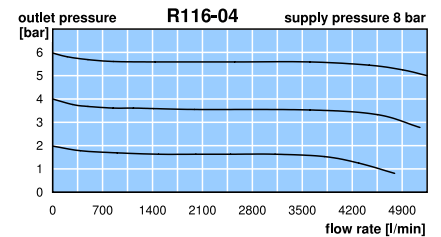
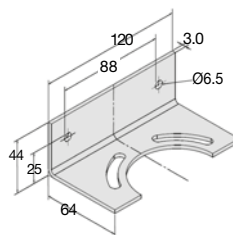
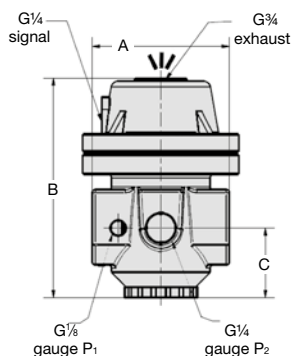
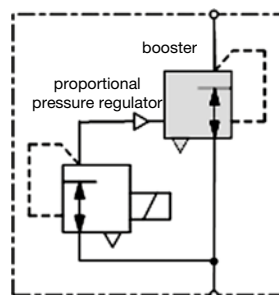
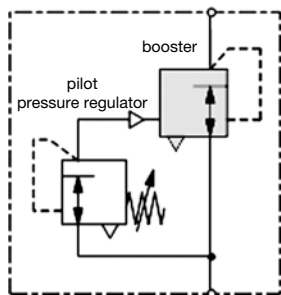
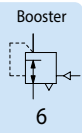

*1 at 8 bar supply pressure, 6 bar outlet pressure and 1 bar pressure drop
*2 02 = 0...2.5 bar, 04 = 0...4 bar, 10 = 0...10 bar, 16 = 0...16 bar, 25 = 0...25 bar

Gauges: see chapter for measuring devices

PDF CAD
www.aircom.net

Order example:
R116-02

PRECISION VOLUME BOOSTER WITH HIGH VOLUME FLOW

R200 / R201

Description	The volume booster amplifies the volume at a 1:1 ratio of pilot pressure to outlet pressure. The pilot pressure has no constant bleed. The bias spring at booster R200 generates a positive shift of the pressure range between pilot pressure and outlet pressure. Booster R201 with great relief capacity is a combination of two R200 boosters. When the output pressure increases above the signal pressure, the diaphragm assembly moves upward to close the supply valve and open the exhaust valve. Excess output pressure exhausts through the exhaust port until it reaches the setpoint.	
Media	compressed air or non-corrosive gases	Supply pressure max. 17 bar
Pilot pressure	max. 10 bar, pilot port G $\frac{1}{4}$ at R200; $\frac{1}{4}$ " NPT at R201	
Accuracy	at supply pressure variation of 7 bar: < 20 mbar pressure deviation	Response sensitivity 30 mbar
Air consumption	without constant bleed	Relieving function relieving, optionally non-relieving
Relief capacity	1 800 l/min at 0.3 bar overpressure above setpoint at R200, 9 000 l/min at R201	
Gauge port	G $\frac{1}{4}$ on both sides of the body at R200; $\frac{1}{4}$ " NPT at R201	Mounting position any
Temperature range	0 °C to 90 °C / 32 °F to 194 °F, for appropriately conditioned compressed air down to -40 °C / -40 °F	
Material	Body: aluminium die-cast Elastomer: NBR/Buna-N-/Dacron, optionally FKM Inner valve: stainless steel, cadmium-plated steel and brass	

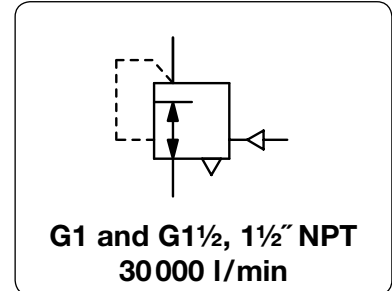

Dimensions			K _v -value	Flow rate	Connection thread	Supply pressure	Pressure range	Order number
A	B	C						
mm	mm	mm	(m ³ /h)	m ³ /h*1	l/min*1	G	max. bar	bar

Booster w. high volume flow									
supply pressure max. 17 bar, relieving, without constant bleed, transmission ratio 1:1									
R200									
141	198	57	11.4	1 680	28 000	G1	17	0...10	R200-08I
141	198	57	12.2	1 800	30 000	G1½	17	0...10	R200-12I

Booster w. high exhaust capacity									
supply pressure max. 17 bar, relieving, without constant bleed, transmission ratio 1:1									
R201									
250	240	57	12.2	1 800	30 000	1½" NPT	17	0...10	R201-12I



R200



R201

Special options, add the appropriate letter

NPT	connection thread	for R200	R200-..IN
non-relieving	without relieving function	for R200	R200-..IK
tapped exhaust	connection thread G $\frac{3}{8}$	for R200	R200-..IX12
FKM elastomer		for R200	R200-..IV

Accessories, enclosed

pressure gauge	Ø 63 mm, 0...*2 bar, G $\frac{1}{4}$	MA6302-..*2
adapter	$\frac{1}{4}$ " NPT male / G $\frac{1}{4}$ female	for R201 VP-0202N
mounting bracket	made of steel	for R200 BW00-41

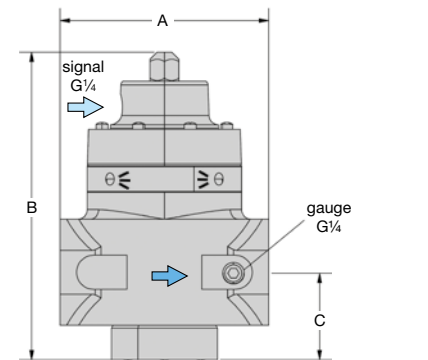

R200

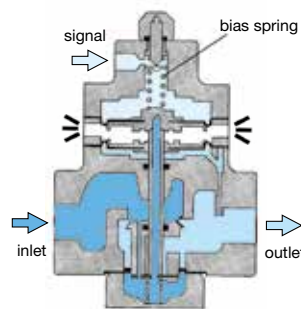

cross-section

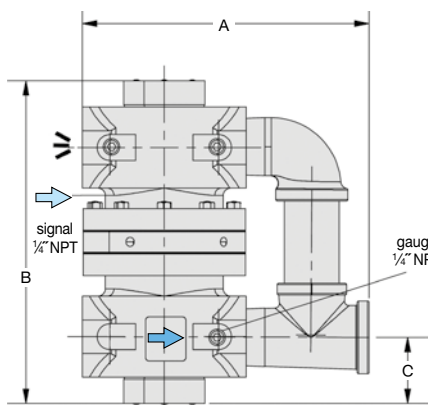

R201

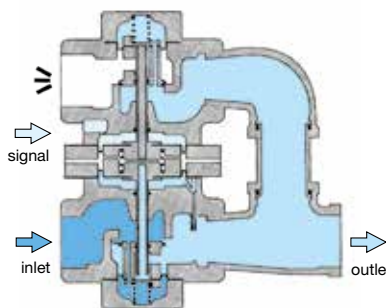

cross-section

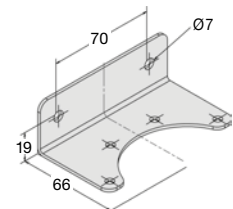

BW00-41

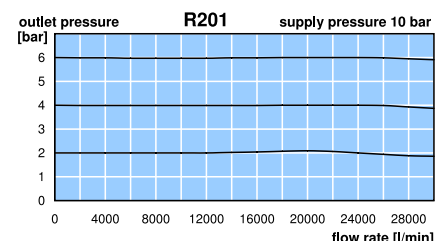

*1 at 10 bar supply pressure and 2.8 bar outlet pressure
*2 02 = 0...2.5 bar, 04 = 0...4 bar, 06 = 0...6 bar, 10 = 0...10 bar, 16 = 0...16 bar

Gauges: see chapter for measuring devices

PDF CAD
www.aircom.net

Order example:
R200-08I

LOW PRESSURE VOLUME BOOSTER UP TO 1 BAR, SUPPLY PRESSURE MAX. 20 BAR RZ-J

Description	Highly sensitive diaphragm low pressure volume booster with excellent regulating characteristics.		
Media	compressed air or non-corrosive gases		
Supply pressure	max. 20 bar depending on the accuracy: the smaller P ₁ the higher the accuracy max. 10 bar at pressure range < 150 mbar		
Pilot pressure	max. 1000 mbar		
Air consumption	without constant bleed		
Relieving function	non-relieving, optionally relieving		
Accuracy	at max. flow rate < e.g. 10% pressure deviation of full scale		
Adjustment	manual by turning the spindle under the cover of the spring cage		
Gauge port	not available		
Mounting position	any		
Temperature range	-20 °C bis 60 °C / -4 °F to 140 °F		
Material	Body: SG cast iron GGG50, GGG40 at G2	Elastomer: NBR/Buna-N, optionally FKM	Inner valve: brass and stainless steel
	Spring cage: aluminium		

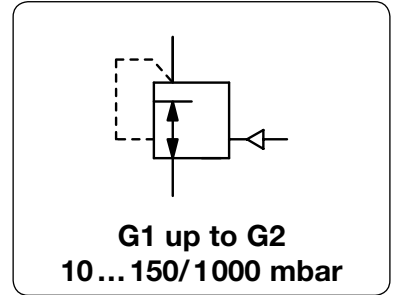

Dimensions			Accuracy %	Nominal size DN	Flow rate l/min*1	P ₁ max. bar*2	Connection thread G	Pressure range mbar	Order number
A	B	C							

Low pressure volume booster						supply max. 20 bar, non-relieving, 1:1 transmission ratio	RZ-J			
100	245	30	10	17	1800	10	G1	15... 110	RZ1-08J	
			5		3300			180... 1000	RZ3-08J	
185	245	30	10	17	2700	10	G1½*3	15... 110	RZ1-12J	
			5		5000			180... 1000	RZ3-12J	
254	460	80	10	34	15000	10	G2	10... 350	RZ1-16JF	
			5		28000			350... 1000	RZ2-16JF	



RZ1-08J

Special options, add the appropriate letter

relieving	with relieving function	RZ . . . R
FKM elastomer		RZ . . . V
flange connection	see chapter for SST devices / flanges (not for RZ.-16J)	RZ . . . F.
carbon dioxide	CO ₂	RZ . . . 03
argon	Ar	RZ . . . 05
nitrogen	N ₂	RZ . . . 07
helium	He	RZ . . . 09
hydrogen	H ₂	RZ . . . 11
methane	CH ₄	RZ . . . 13
oxygen	O ₂	RZ . . . 15
propane	C ₃ H ₆	RZ . . . 16
nitrous oxide	N ₂ O	RZ . . . 17

up to 16 bar



RZ1-16JF

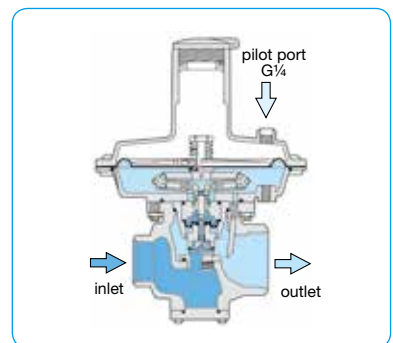
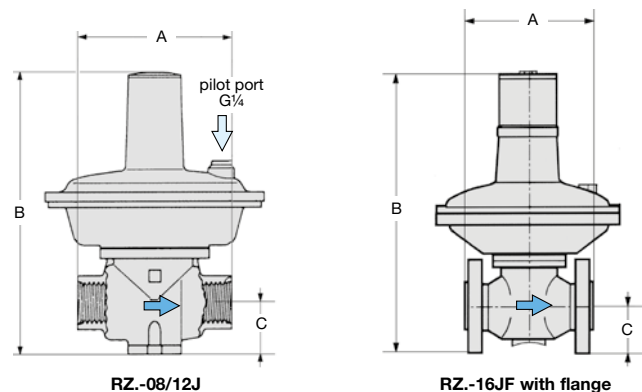
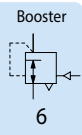

*1 at 4 bar supply pressure and max. outlet pressure *2 see description above *3 G1 thread at inlet

Description	Pilot-operated regulator adapted for control by small remote pilot regulator or by proportional pressure valve. Ideal for continuous high-capacity requirements where reduced pressure must be held constant over wide variations in flow. Booster with diaphragm up to regulator size G1½, with piston from regulator size G2 on. The booster is silicone-free.	
Media	compressed air or non-corrosive gases	
Supply pressure	max. 21 bar	
Pilot pressure	max. 18 bar	
Pilot port	G¼ at regulator size G¼ and G¾, pilot port G¼ from regulator size G½ on	
Air consumption	approx. 1 l/min of pilot signal	
Relieving function	relieving as standard, optionally non-relieving	
Gauge port	G¼ on both sides of the body	
Temperature range	0 °C to 50 °C / 32 °F to 122 °F	up to 80 °C / 176 °F at G3
Material	Body: zinc die-cast, aluminium at G3 Diaphragm: NBR/Buna-N, optionally FKM	Mounting position any Inner valve: brass Bottom screw: reinforced nylon

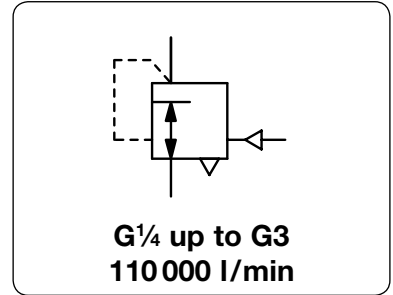

Dimensions			Nominal size	K _v -value	Flow rate		Connection thread	Order number
A	B	C	DN	(m³/h)	m³/h*1	l/min*1	G	
mm	mm	mm						

Booster			supply pressure max. 21 bar, outlet pressure 0.2 ... 18 bar with constant bleed, transmission ratio 1:1, relieving			R119-J		
70	86	35	5	2.1	102	1700	G¼	R119-02J
70	86	35	10	2.8	150	2500	G¾	R119-03J
83	98	37	15	5.0	340	5600	G½	R119-04J
113	123	49	20	7.6	540	9000	G¾	R119-06J
113	123	49	25	8.4	600	10000	G1	R119-08J
125	132	48	32	9.2	660	11000	G1¼ ³	R119-10J
125	132	48	40	10.0	720	12000	G1½	R119-12J
186	225	79	50	35.4	2520	42000	G2	R119-16J
186	225	79	65	37.1	2640	44000	G2½	R119-20J
214	282	95	80	56.0	6600	110000	G3	R119-24J



Special options,	add the appropriate letter	
NPT	connection thread	R119-...JN
non-relieving	without relieving function	R119-...JK
FKM elastomer		R119-...JX64
		R119-24JX64
without constant bleed	insided the pilot chamber	R119-...JX71
flange connection	see chapter for SST devices / flanges	R119-...JF
external feedback	for faster and increased accuracy	R119-24JX27
pre-pressure regulation	340 mbar, advisable if P ₁ is close to P ₂	R119-24JX06

Accessories, enclosed		
pressure gauge	Ø 50 mm, 0... ^{*2} bar, G¼	for G¼ to G½
	Ø 63 mm, 0... ^{*2} bar, G¾	for G¾ to G3
mounting bracket	made of steel	for G¼ and G¾
		for G½
		for G¾ to G1½

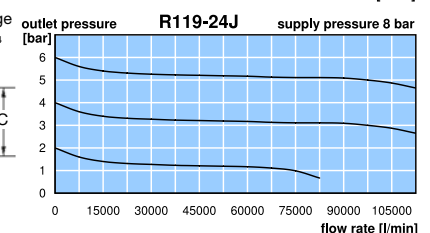
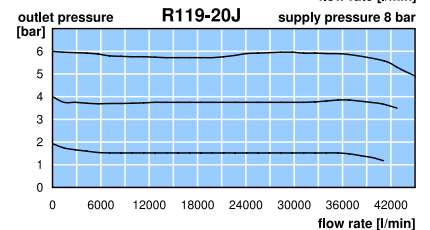
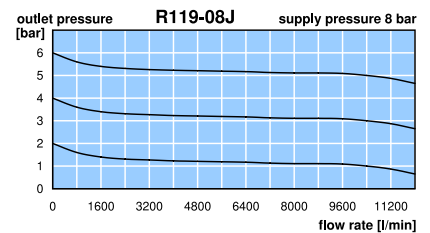
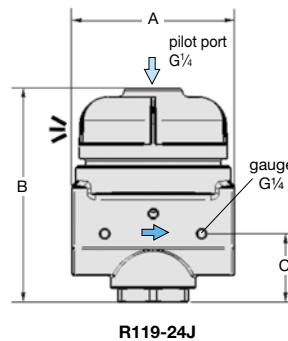
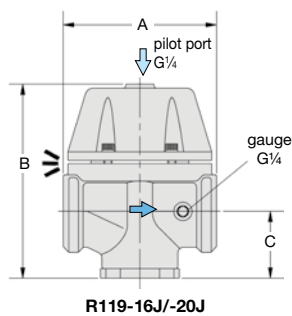
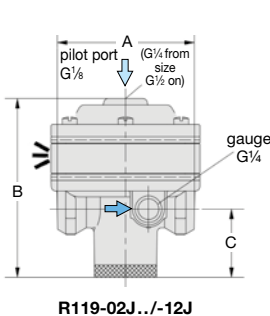
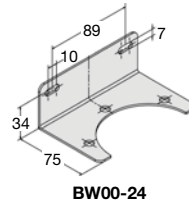
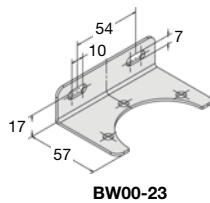
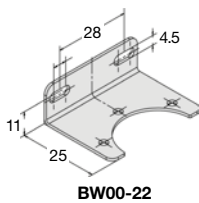
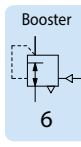

*1 at 8 bar supply pressure, 6 bar outlet pressure and 1 bar pressure drop
*2 02 = 0...2.5 bar, 04 = 0...4 bar, 10 = 0...10 bar, 16 = 0...16 bar, 25 = 0...25 bar

HIGH PRESSURE VOLUME BOOSTER WITH TRANSMISSION RATIO, UP TO 310 BAR

RH3-J

Description	Highly reliable high pressure volume booster with diaphragm and high flow. In addition, the booster features high sensitivity and excellent regulating characteristics.		
Media	compressed air, non-corrosive gases or liquids		
Supply pressure	max. 260 bar, optionally 345 bar or 310 bar		
Test pressure	150% of maximum supply pressure according to regulations ANSI / ASME B31.3		
Pilot pressure	see chart, pilot port G $\frac{1}{8}$ "		
Leakage rate	< 1x 10 ⁻⁴ mbar l/s He		
Air consumption	without constant bleed		
Relieving function	non-relieving		
Gauge port	not available, optionally 1/4" NPT at inlet and outlet		
Mounting position	any		
Temperature range	-25 °C to 100 °C / -13 °F to 212 °F		
Material	Body: brass, optionally stainless steel	Elastomer: FKM	Inner valve: PTFE, brass or optionally stainless steel

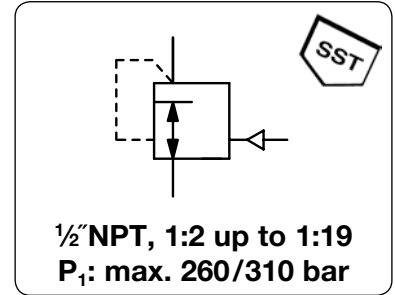

Dimensions			K _v -value	Flow rate	Pilot pressure	Pressure range	Transmission ratio	Order number
A	B	C	(m ³ /h)	m ³ /h*1	l/min*1	max. bar	signal : outlet	

High pressure booster			supply pressure max. 260 bar, non-relieving, 1/2" NPT without constant bleed, without gauge port				RH3-J		
76	170	45	1.7	420	7000	21	3 ... 42	1 : 2	RH3-J402
						17	5 ... 70	1 : 4	RH3-J404
						5	3 ... 42	1 : 8	RH3-J408
						5	5 ... 70	1 : 13	RH3-J413
						5	10 ... 104	1 : 19	RH3-J419

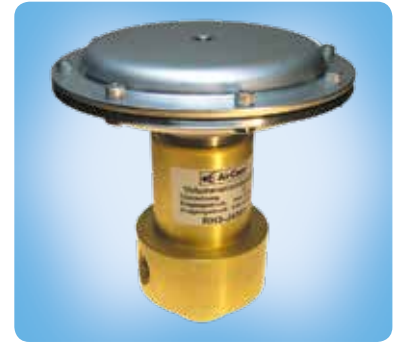

RH3-J

Special options, add the appropriate letter

1/4" NPT	connection thread		RH3-J6 . .
SST, 310 bar	body made of stainless steel 316		RH3-J . . .S1
for liquids	no filter at inlet port		RH3-J . . .W
gauge port	1/4" NPT for inlet and outlet		RH3-J . . .M
brass gauge	for brass body, on the input side	MHM	output side RH3-J . . .MGM
SST gauge	for SST body, on the input side	MH	output side RH3-J . . .MG

Accessories, enclosed

set of brackets	for panel mounting	1129
-----------------	--------------------	------

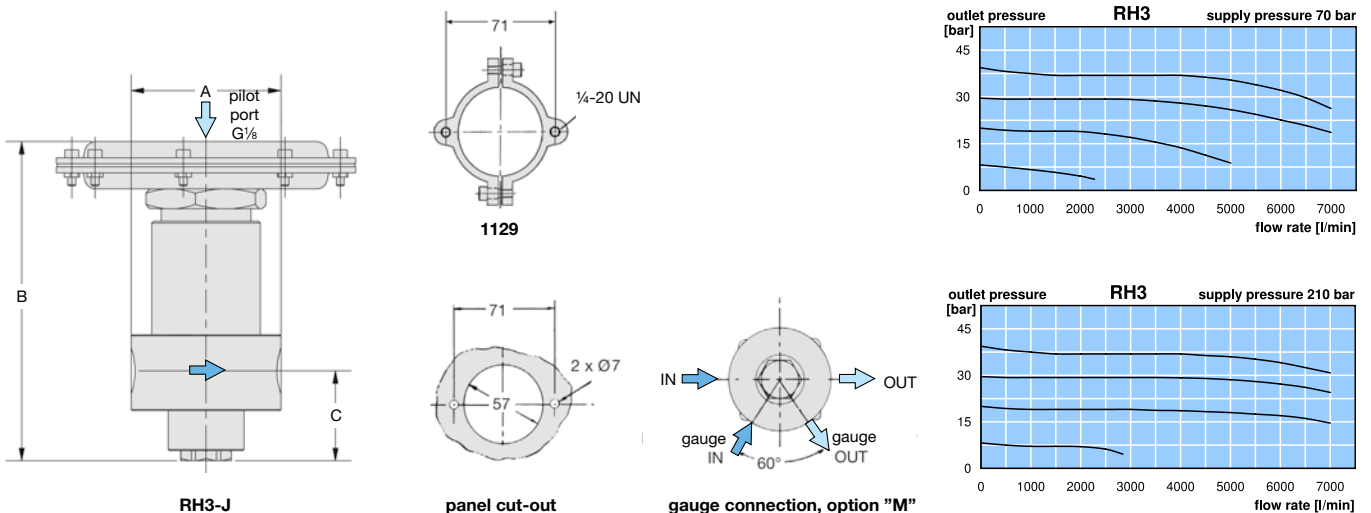
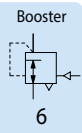

*1 at 210 bar supply pressure and 40 bar outlet pressure

Gauges: see chapter for measuring devices

PDF CAD
www.aircom.net

Order example:
RH3-J402

LOW PRESSURE VOLUME BOOSTER UP TO 350 MBAR

RGDJ-J/RGB4-J

Description	Highly sensitive low pressure volume booster with diaphragm and a 1:1 transmission ratio. Zero shut-off prevents the outlet pressure from increasing when there is no flow circulating.		
Media	compressed air or non-corrosive gases		
Supply pressure	max. 400 mbar at RGDJ-J,	max. 4 bar at RGB4-J	
Pilot pressure	max. 100 mbar at RGDJ-J,	max. 350 mbar at RGB4-J,	pilot port G $\frac{1}{4}$
Air consumption	without constant bleed non-relieving		
Relieving function	non-relieving		
Accuracy	at maximum volume flow: < 20% pressure deviation of full scale		
Gauge port	not available, optionally G $\frac{1}{4}$ on one side of the body from regulator size G $\frac{3}{4}$ on any		
Mounting position	any		
Temperature range	RGDJ-J: -20 °C to 70 °C / -4 °F to 158 °F	RGB4J: -15 °C to 60 °C / -4 °F to 140 °F	
Material	Body: aluminium	Inner valve: aluminium and plastic	Elastomer: NBR/Buna-N

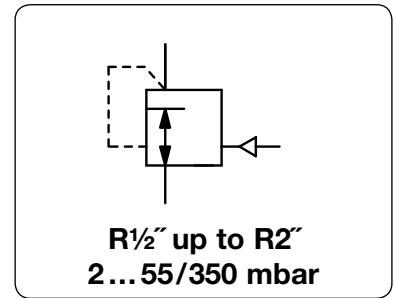

Dimensions			Nominal size	Kv-value	Flow rate	Connection thread	Pressure range	Order number
A	B	C	DN	(m ³ /h)	m ³ /h*1	l/min*1	R	mbar

Low pressure booster <i>P₁ max. 400 mbar</i>								non-relieving, without constant bleed, transmission ratio 1:1	RGDJ-J
100	120	30	15	0.66	12	200	½"	2... 55	RGDJ-04J
134	166	34	20	1.49	27	450	¾"	5... 160	RGDJ-06J
134	166	34	25	2.6	51	850	1"	5... 160	RGDJ-08J
185	194	45	40	4.9	90	1500	1½"	5... 160	RGDJ-12J
234	219	52	50	6.6	120	2000	2"	5... 100	RGDJ-16J



RGDJ-04J

Low pressure booster <i>P₁ max. 4 bar</i>								non-relieving, without constant bleed, transmission ratio 1:1	RGB4-J
132	174	24	15	0.62	42	700	½"	5... 350	RGB4-04J
190	230	33	25	2.5	168	2800	1"	5... 350	RGB4-08J
190	265	55	40	5	336	5600	1½"	5... 350	RGB4-12J



RGB4-12JM
accessory: gauge

Special options, add the appropriate letter

connection thread G $\frac{1}{4}$ for pressure gauge not for RGDJ-04J RG...M

Accessories, enclosed

pressure gauge Ø 63 mm, 0...*2 mbar, G $\frac{1}{4}$ for R¾" up to R2" MA6302-..*2

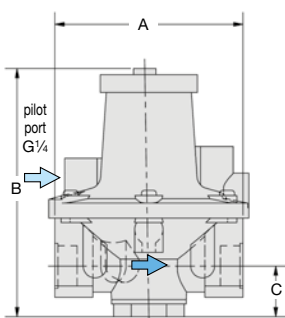

RGDJ-J

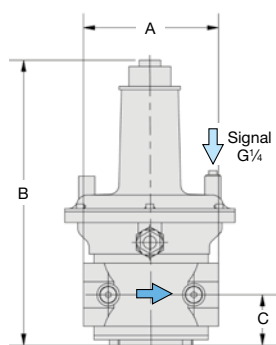

RGB4-J

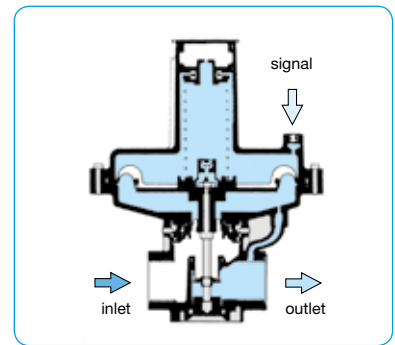
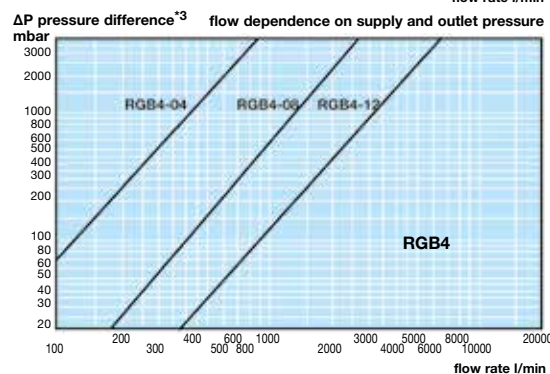
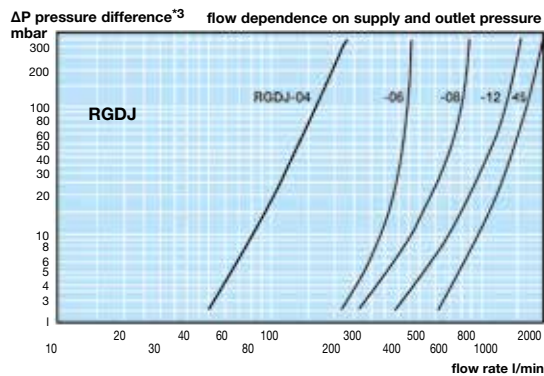

cross section RGB4-J

*1 bei 350 mbar Eingangsdruck und 100 mbar Ausgangsdruck

*2 B6 = 0...60 mbar, C2 = 0...160 mbar, C4 = 0...400 mbar

*3 $\Delta P = P_1 - P_2$ Druckdifferenz von Eingangsdruck und Ausgangsdruck

Gauges: see chapter for measuring devices

PDF CAD
www.aircom.net



Order example:
RGDJ-04J

Description	The pilot pressure regulator / booster regulates the outlet pressure through a signal pressure at ratio of 1:1. Functioning as a pressure regulator the pilot pressure may either be internally inducted from the inlet pressure or externally. The dome chamber is closed by a needle valve. Functioning as a volume booster the dome is controlled by a proportional pressure regulator or a pilot pressure regulator.		
Media	compressed air, non-corrosive gases or liquids		
Supply pressure	max. 25 bar for RL.-0.J1,	max. 100 bar for RL.-0.J2,	max. 40 bar for oxygen, max. 1.5 bar for acetylene
Pilot pressure	max. 24 bar for RL.-0.J1, max. 99 bar for RL.-0.J2, pilot port G¼		
Accuracy	at supply pressure variation of 10 bar: at temperature variation of 3 °C / K:	0.1 bar pressure deviation 1% pressure deviation at internal pilot pressure	
Air consumption	without constant bleed	Relieving function	non-relieving
Gauge port	not available	Mounting position	any, dome preferably mounted up
Temperature range	-20 °C to 100 °C / -4 °F to 212 °F for FKM, -40 °C to 130 °C / -40 °F to 266 °F for EPDM		
Material	Body: brass or stainless steel 1.4571 Inner valve: brass or stainless steel 1.4571	Elastomer: FKM, optionally EPDM	

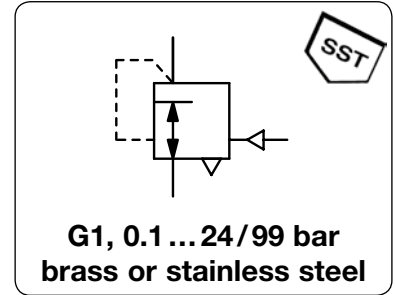

Dimensions			K _v -value	Flow rate	Connection thread	Supply pressure max. bar*2	Pressure range bar	Order number
A	B	C						

Brass pressure regulator								supply pressure max. 25 / 100 bar, non-relieving, without constant bleed, transmission ratio 1:1, FKM		RLM
127	170	54	2.9	340	5600	G1	25	0.1 ... 24		RLM-08J1
				2500	60000	G1	100	0.5 ... 99		RLM-08J2



RLM, made of brass

SST pressure regulator								supply pressure max. 25 / 100 bar, non-relieving, without constant bleed, transmission ratio 1:1, FKM		RLE
127	170	54	2.9	340	5600	G1	25	0.1 ... 24		RLE-08J1
				2500	60000	G1	100	0.5 ... 99		RLE-08J2



RLE, made of stainless steel

Special options, add the appropriate letter

EPDM elastomer		RL.-0.J.E
carbon dioxide	CO ₂	RL.-0.J.03
argon	Ar	RL.-0.J.05
nitrogen	N ₂	RL.-0.J.07
helium	He	RL.-0.J.09
hydrogen	H ₂	RL.-0.J.11
oxygen	O ₂	RL.-0.J.15
propane	C ₃ H ₈	RL.-0.J.16
nitrous oxide	N ₂ O	RL.-0.J.17

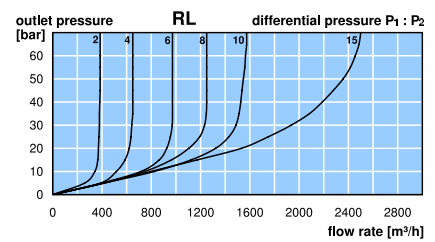
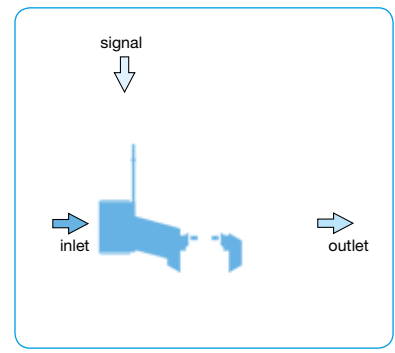
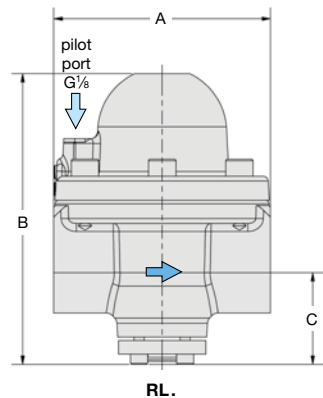
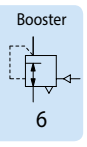

*1 RL.-J1: at 25 bar supply pressure and 5 bar outlet pressure
 RL.-J2: at 85 bar supply pressure and 70 bar outlet pressure
 *2 supply pressure max. 40 bar for oxygen
 supply pressure max. 1.5 bar for acetylene

PDF CAD
www.aircom.net

Order example:
RLM-08J1

BRASS VOLUME BOOSTER, UP TO 50 BAR

R120-J

Description	Solid volume booster made of brass or bronze throughout with a 1:1 transmission ratio. R120-02J2 to R120-08J2 are diaphragm-operated, R120-12J, R120-16J and R120-...J5 are piston-operated.		
Media	compressed air, non-corrosive gases or liquids		
Supply pressure	max. 50 bar, for liquids $\Delta p_{max} = 25$ bar		
Pilot pressure	max. 15 bar for R120-...J2, max. 50 bar for R120-...J5, pilot port G $\frac{1}{4}$		
Air consumption	without constant bleed		
Relieving function	non-relieving, optionally relieving		
Relief size	DN2		
Gauge port	G $\frac{1}{4}$ on both sides of the body, one screw plug supplied		
Mounting position	any		
Temperature range	0 °C to 80 °C / 32 °F to 176 °F for FKM or EPDM 0 °C to 130 °C / 32 °F to 266 °F for high temperature version, for appropriately conditioned compressed air down to -20 °C / -4 °F, optionally low temperature version down to -40 °C / -40 °F		
Material	Body: brass up to G $\frac{1}{2}$, bronze from G $\frac{3}{4}$ on	O-rings: FKM, optionally EPDM	Inner valve: brass
	Diaphragm: NBR/Buna-N with PTFE coating		

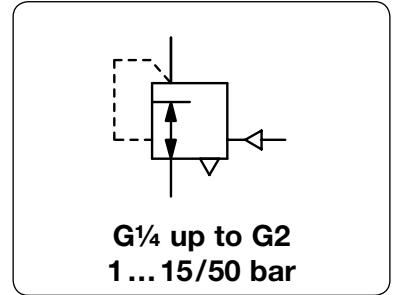

Dimensions	Regul. system	K _v	Flow rate	Connection thread	Pilot pressure	Pressure range	Order number
A B C	D: diaphragm P: piston	value (m ³ /h)	m ³ /h*1 l/min*1	G	max. bar	bar	

Booster made of brass							supply pressure max. 50 bar, non-relieving, without constant bleed, transmission ratio 1:1		R120-J	
64	79	38	D	0.35	25	420	G $\frac{1}{4}$	15	1...15	R120-02J2
64	92	38	P					50	1...50	R120-02J5
80	86	38	D	1	72	1200	G $\frac{1}{2}$	15	1...15	R120-04J2
80	107	38	P					50	1...50	R120-04J5
116	136	65	D	3.5	252	4200	G $\frac{3}{4}$	15	1...15	R120-06J2
116	150	65	P					50	1...50	R120-06J5
116	136	65	D	4.2	300	5000	G1	15	1...15	R120-08J2
116	150	65	P					50	1...50	R120-08J5
195	140	84	P	11.8	840	14000	G1 $\frac{1}{2}$	50	1...50	R120-12J5
195	190	84	P	12.6	900	15000	G2	50	1...50	R120-16J5



R120-02J2, accessory: gauge



R120-04J2, accessory: gauge



R120-08J2, accessory: gauge

Special options, add the appropriate letter

diaphragm relieving	for R120-02J2 up to R120-08J2		R120-...J.R
piston relieving	for R120-12J, R120-16J and R120-...J5		R120-...J.R
down to -40 °C	low temperature version		R120-...J.X51
up to 130 °C	high temperature version		R120-...J.X54
EPDM elastomer	not for G2		R120-...J.E
tapped exhaust			R120-...J.RX12
nitrogen N ₂ : 07	carbon dioxide CO ₂ : 03	argon Ar: R120-...J.05	
helium He: 09	hydrogen H ₂ : 11	methane CH ₄ : R120-...J.13	
natural gas 14	oxygen O ₂ : 15	propane C ₃ H ₈ : R120-...J.16	
	nitrous oxide N ₂ O: 17	water H ₂ O: R120-...J.W	

Accessories, enclosed

pressure gauge	Ø 50 mm, 0... ^{*2} bar, G $\frac{1}{4}$	for G $\frac{1}{4}$ and G $\frac{1}{2}$	MA5002-..*2
pressure gauge	Ø 63 mm, 0... ^{*2} bar, G $\frac{1}{4}$	for G $\frac{3}{4}$ up to G2	MA6302-..*2
mouting bracket	made of steel	for G $\frac{3}{4}$ and G1	BW00-42
		for G1 $\frac{1}{2}$ and G2	BW00-43

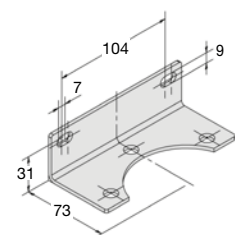

BW00-42

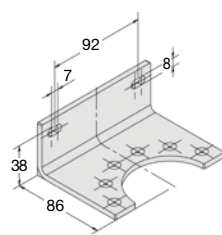

BW00-43

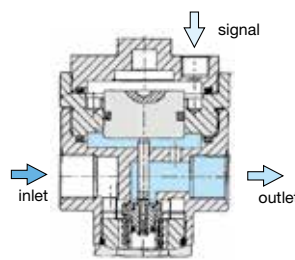

cross-section: with piston

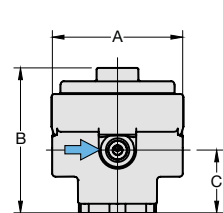

R120-02/-04J.

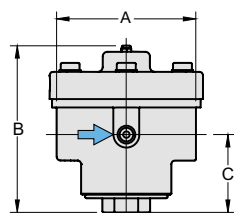

R120-06/-08/-12/-16J.

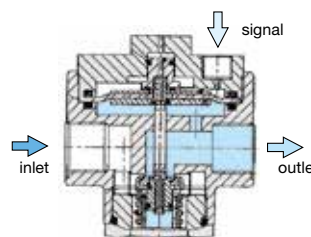

cross-section: with diaphragm

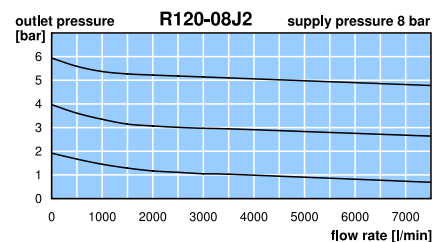
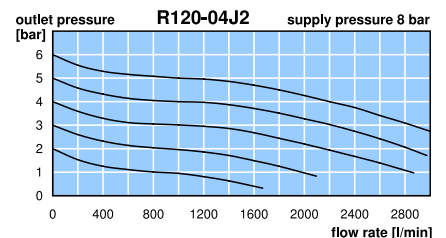

*1 at 8 bar supply pressure, 6 bar outlet pressure and 1 bar pressure drop
*2 02 = 0...2.5 bar, 06 = 0...6 bar, 10 = 0...10 bar, 16 = 0...16 bar, 60 = 0...60 bar

Gauges: see chapter for measuring devices

PDF CAD
www.aircom.net

Order example:
R120-02J2

Description	The air amplifier compresses air or nitrogen from a standard pressure of 10 bar max. to the desired outlet pressure of 60 bar max. This is realised by cylinders with different ratios - simple, safe and economical. No electrical installation is required and there is no energy consumption once the final pressure has been reached. Service life 3 million cycles, full load operation 12 min max. per hour.		
Media	lubricated, unlubricated and 50 µm filtered compressed air or nitrogen		
Mounting position	any		
Power device	Cylinder with integrated reversing valve, check valve and silencer. The pressure will be increased selective to the consumer. No energy consumption once final pressure is attained.		
Drive pressure P_A	system air to drive the air amplifier, 2...10 bar		
Supply pressure P₁	max. 12 bar, for instance nitrogen or compressed air		
Outlet pressure P₂	amplified outlet or operating pressure of 20 bar to 100 bar maximum		
Continuous operation	20% of the diagram values should maximally be realised at permanent running		
Temperature range	0 °C to 60 °C / 32 °F to 140 °F		
Material	Body: aluminium	Sound level	max. 79 dB (A)
		Seals:	NBR/Buna-N

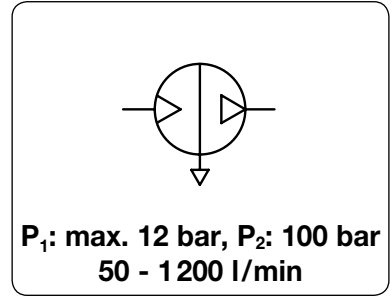

Dimensions			Weight kg	Connection thread G	Transmission ratio P _A : P ₂	Flow rate l/min	P ₂ max. bar	Order number
A mm	B mm	C mm						

Pressure booster / Air amplifier								supply pressure P ₁ , max. 12 bar, for compressed air	AM
								drive pressure P _A 2...10 bar	
86	343	84	3.3	G ³ / ₈	1 : 2	580 ^{*1}	20	AM20-0580	
187	324	135	8.5	G ¹ / ₂	1 : 2	960 ^{*1}	20	AM20-0960	
285	427	180	21	G ³ / ₄	1 : 2	1200 ^{*1}	20	AM20-1200	
180	392	135	8.5	G ¹ / ₂	1 : 3	230 ^{*2}	32	AM32-0230	
80	220	80	2.2	G ³ / ₈	1 : 4	50 ^{*3}	40	AM40-0050	
251	471	176	16	G ³ / ₈	1 : 5	360 ^{*4}	60	AM60-0360	
180	421	135	20	G ¹ / ₄	1 : 10	280 ^{*5}	100	AM100-0250	

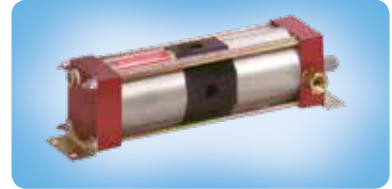

Special options, add the appropriate letter

- unlubricated operation seals** FEC seals for dry compressed air or nitrogen
AM T
- Ex-Atex** e.g. Ex II 3G/3D IIB x, more specifications possible
AM EX
- pressure booster for gas** up to max. 1500 bar outlet pressure
AM
- pressure booster for liquids**
AM

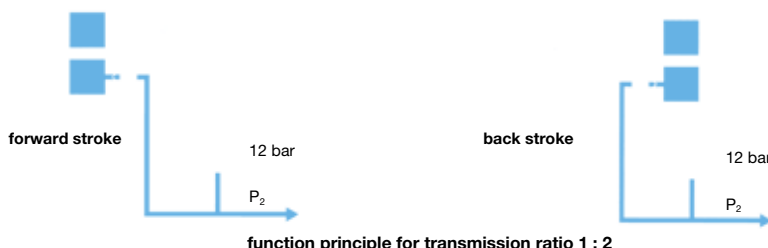
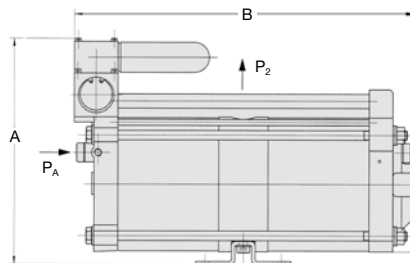
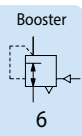

*1 at 6 bar supply and 8 bar outlet pressure under full load
 *2 at 8 bar supply and 20 bar outlet pressure under full load
 *3 at 6 bar supply and 16 bar outlet pressure under full load
 *4 at 8 bar supply and 30 bar outlet pressure under full load
 *5 at 8 bar supply and 40 bar outlet pressure under full load

Calculation examples can be found in the appendix

PDF CAD
www.aircom.net

Order example:
AM20-0580

AIR AMPLIFIER STATION WITH TANK

AP

Description	The air amplifier compresses air or nitrogen from a standard pressure of 10 bar max. to the desired outlet pressure of 40 bar max. This is realised by cylinders with different ratios - simple, safe and economical. No electrical installation is required and there is no energy consumption once the final pressure has been reached. Service life 3 million cycles, full load operation 12 min max. per hour.		
Media	lubricated, unlubricated and 50 µm filtered compressed air		
Amplifier station	The pressure booster has an additional tank, pressure regulator, filter, gauge, relief valve and switch-on valve. Pressure pulsation rates are low, air consumption peaks are compensated and the operating pressure can be adjusted.		
Drive pressure P_A	system air to drive the air amplifier, 2...10 bar		
Supply pressure P₁	max. 12 bar, for instance nitrogen or the system air		
Outlet pressure P₂	amplified outlet or operating pressure of 20 bar to 40 bar maximum		
Temperature range	0 °C to 60 °C / 32 °F to 140 °F	Sound level	max. 79 dB (A)
Material	Body: aluminium	Seals: NBR/Buna-N	Tank: coated steel, SST at AP40-0050

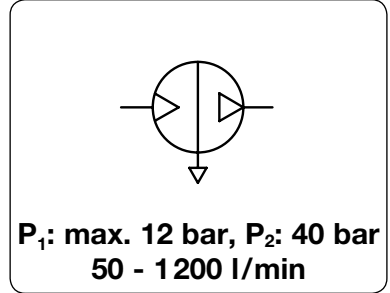

Dimensions			Weight	Tank	Connection	Transmission	Flow	P ₂	Order
A	B	C	kg	volume	thread	ratio	rate	max.	number
mm	mm	mm		l	drive P ₁ / P ₂	P _A : P ₂	l/min ¹	bar ⁵	

Air amplifier station				supply pressure P ₁ max. 12 bar, for compressed air drive pressure P _A 2...10 bar			AP			
220	400	360	13	3	G ³ / ₈	G ³ / ₈	1 : 2	580 ^{*1}	20	AP20-0580
235	400	360	16	3	G ¹ / ₂	G ¹ / ₂	1 : 2	960 ^{*1}	20	AP20-0960
656	844	381	49	40	G ³ / ₈	G ¹ / ₂	1 : 2	1200 ^{*1}	20	AP20-1200
655	844	381	58	40	G ¹ / ₂	G ¹ / ₂	1 : 3	230 ^{*2}	20	AP20-0230
365	400	133	5.3	0.8	G ³ / ₈	G ³ / ₈	1 : 4	50 ^{*3}	40	AP40-0050
655	844	381	45	40	G ¹ / ₂	G ³ / ₈	1 : 5	360 ^{*4}	40	AP40-0360



Special options, add the appropriate letter

- unlubricated operation seals FEC seals for dry compressed air or nitrogen AP...T
- Atex e.g. Ex II 3G/3D IIB x, further specifications possible AP...EX
- pressure booster for gasbis P₂ max. 1500 bar AP...6

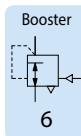
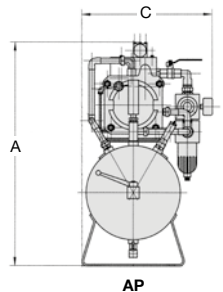
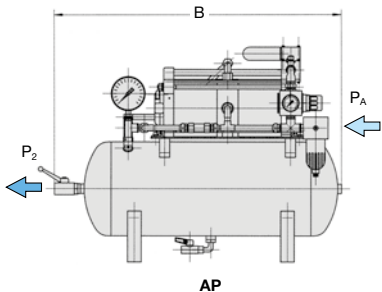

Performance diagrams for full load operations, max. 12 min/h. 20% of the values at permanent running

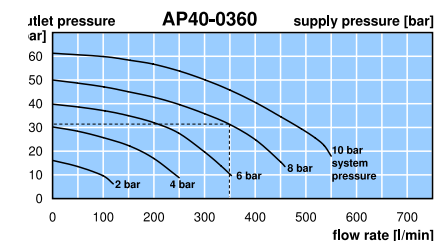
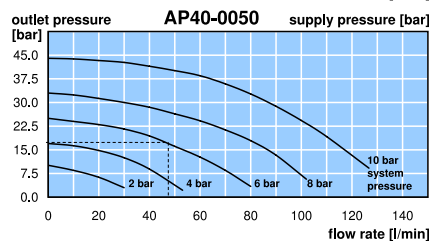
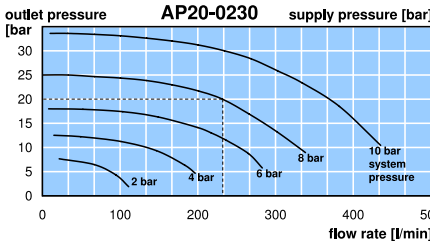
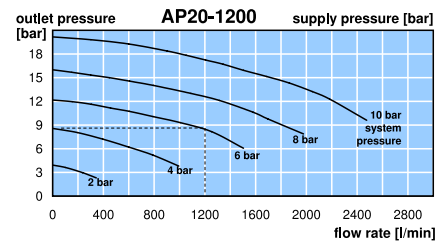
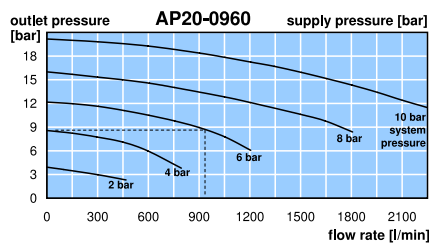
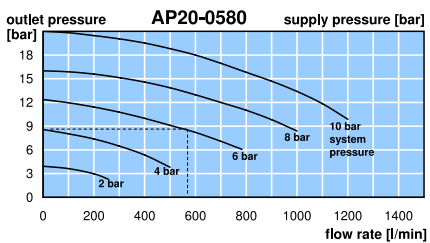

*1 at 6 bar supply and 8 bar outlet pressure under full load
 *2 at 8 bar supply and 20 bar outlet pressure under full load
 *3 at 6 bar supply and 16 bar outlet pressure under full load
 *4 at 8 bar supply and 30 bar outlet pressure under full load
 *5 outlet pressure P₂ limited by the pressure stage of the accumulator, higher pressure ranges on request

Calculation examples can be found in the appendix

PDF CAD
www.aircom.net

Order example:
AP20-0580

Description	The pressure booster doubles the system pressure of e.g. 5 bar to an outlet pressure of 10 bar. The pumping force of two cylindrical chambers compresses the air down to the set outlet pressure within the third chamber while the fourth chamber is vented. Upon reaching the outlet pressure it is turned off, when falling below it is turned on automatically. Pressure boosters are used for occasional demand of compressed air.	
Media	lubricated and 50 µm filtered compressed air	Mounting position any
Drive	double piston intensifier, ratio 1:2	Reversing, check and switching valves provide for automatic control. Life time approx. 20 million switching cycles.
Inlet pressure P₁	2...8 bar	Outlet pressure P₂ 4...16 bar
Air tanks	are recommended. They compensate pressure fluctuations and allow short-term high volume flows. See circuit below.	
Tank filling time	is a measure of booster performance. To reduce the filling time of the tank, it has to be prefilled with input pressure P ₁ . See circuit below.	
Temperature range	-5 °C to 50 °C / 23 °F to 122 °F	
Material	Cylinder: anodized aluminium	seals: NBR/Buna-N

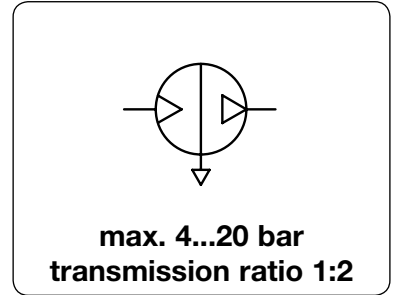

Dimensions			Weight	Connection	Transmission	Flow	Fill	Pressure	Order
A	B	C	kg	thread	ratio	rate	time	range	number
mm	mm	mm		G	P _A : P ₂	l/min*1	s	bar	

Pressure booster									
P ₁ max. 8 bar, for compressed air									
AB									
100	192	70	1.5	G½	1 : 2	130	30	4...16	AB040
117	284	90	3.0	G¾	1 : 2	260	15	4...16	AB063
176	468	155	12	G½	1 : 2	440	6	4...16	AB100



AB040

Pressure booster with regulator and gauge									
P ₁ max. 8 bar, for compressed air									
AB-D									
100	192	126	1.5	G½	1 : 2	130	30	4...16	AB040D
117	284	168	3.0	G¾	1 : 2	260	15	4...16	AB063D
176	468	218	12	G½	1 : 2	440	6	4...16	AB100D



AB040D

Accessories, enclosed

Mounting plate	made of steel, central attachment below	for AB040	BW00-49
		for AB063	BW00-50
Mounting bracket	made of steel, mounting at the side, 1 piece	for AB100	BW00-51

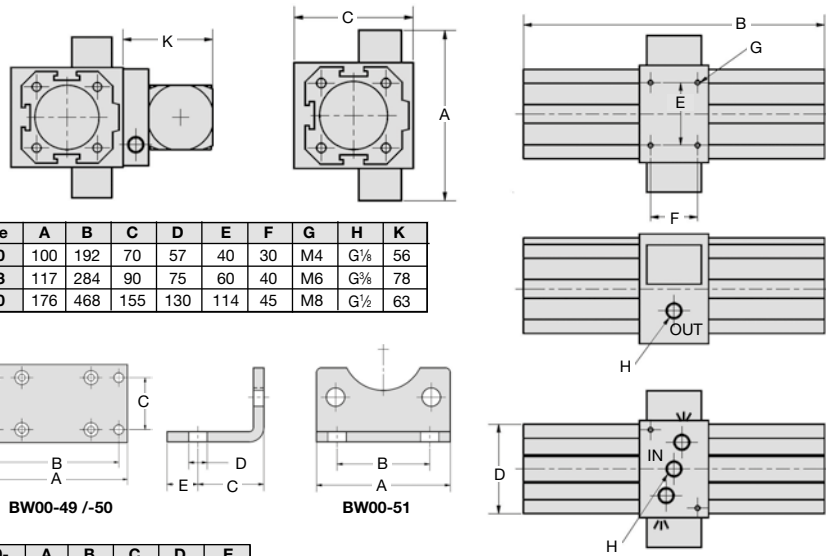
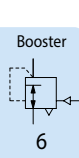

Device	A	B	C	D	E	F	G	H	K
AB040	100	192	70	57	40	30	M4	G½	56
AB063	117	284	90	75	60	40	M6	G¾	78
AB100	176	468	155	130	114	45	M8	G½	63

BW00-	A	B	C	D	E
49	82	72	30	45	5,5
50	110	98	53	70	M8
51	65	45	32	9	15

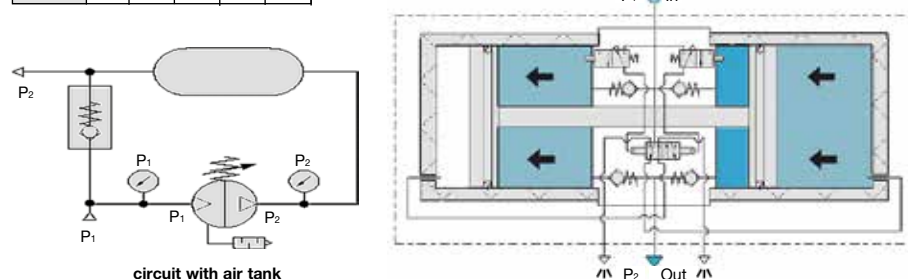

*1 at P₂ = 8 bar and 1 bar pressure drop

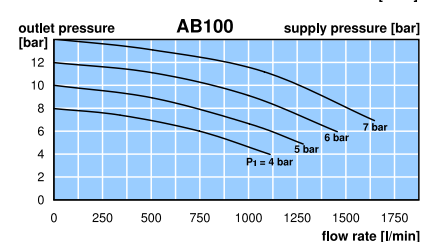
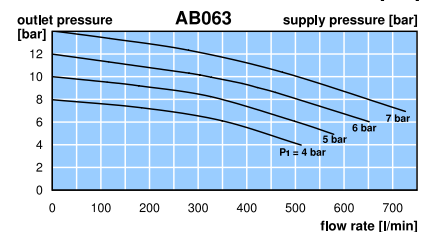
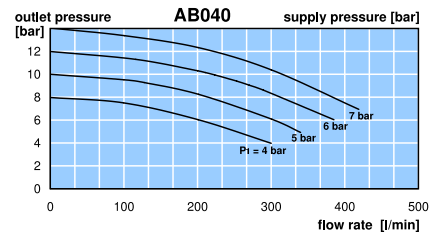
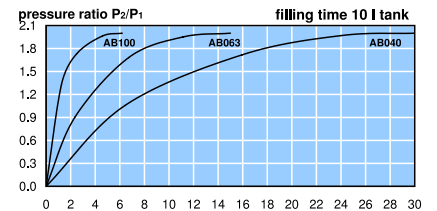

Pressure booster with 2 l to 20 l tank on request

PDF CAD
www.aircom.net

Order example:
AB040